



**fiberon**  
**HORIZON PLUS™**  
*Ultra Low Maintenance Composite Railing*

*Installation Guidelines*



*Provincial Top Rail Profile*



*Mission Top Rail Profile*

# Fibron Horizon™ Plus

Fibron® Horizon™ Plus Railing systems are designed to work with a number of different decking materials and surfaces. Before initiating any project, obtain a copy of your local building codes and understand them thoroughly. Local building code requirements will always supersede any and all suggested procedures and measurements in the following installation guideline.

*Note: For more detailed instructions visit us online at [www.fibrondecking.com](http://www.fibrondecking.com)*

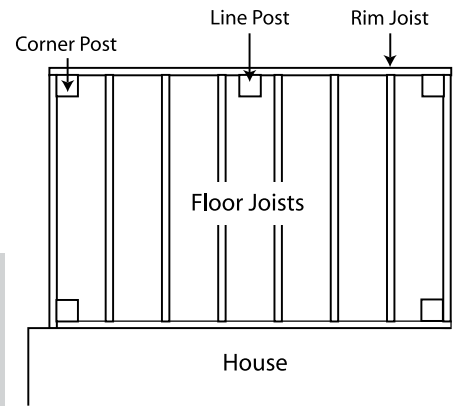

**Figure 1**

## POST INSTALLATION

Determine where the railing posts will be positioned by using a scaled drawing of your project. For proper aesthetics, divide the perimeter dimensions evenly so that posts are spaced equally. To optimize post placement, additional joists or alternative locations may be required. Posts may be installed by using one of four methods. Choose the method or methods that best suit your particular project.

Fibron® guardrail systems should only be secured to code compliant posts. Securing a guardrail to another structure (i.e. building) is not recommended (Fig. 1).

*Note: The inside measurement between posts cannot exceed 96" for 8' section and 72" for 6' section.*

### Post Sleeve over wood post

Use the post sleeve method to install railing directly to a wooden 4"x 4" deck post. This is ideal for new deck construction methods that attach the rim joist directly to the 4"x 4" deck support posts, where wood 4" x 4" deck support posts extend through the deck serving as rail posts (Fig. 2), or in those code compliant applications where the use of existing 4"x 4" wooden rail posts is desired.

1. Ensure 4"x 4" wooden posts are code compliant and, where possible, spaced equally for the best looking application.
2. Determine the desired height of post sleeve. Typically, the height is no less than 2" above the top of the finished railing system. This ensures the proper placement of the post caps that slide down over the top of the post sleeve.
3. Cut the post sleeve to the desired height.
4. The wood post should be approximately 1" shorter than the height of the post sleeve. Cut wood posts as necessary.
5. After decking is installed, slide post sleeve over the wood 4" x 4" post (Fig. 2).

### Post Sleeve Mount (Kits sold separately)

Use the Post Sleeve Mount to install post sleeves directly onto the deck or porch surface. Post Sleeve mounts are available for concrete or wood/composite surfaces. When installing a post sleeve mount on a concrete surface, the support system is anchored into the concrete. When installed on a wood or composite deck, the support system is installed after the deck surface has been attached. Follow these guidelines to complete the post installation:

#### For Concrete: (Fig 3)

1. Determine the desired location(s) and finished height of the post sleeve from the deck surface.
2. Trim the post sleeve to the desired length.
3. Ensure the treated 4"x 4" (generally 3.5" x 3.5" actual) wood post is structurally sound and code compliant. Trim sides to 3.5" if necessary.
4. Trim the length of the 4"x 4" wood post. The wood post length is typically 1-2" shorter than the post sleeve length.

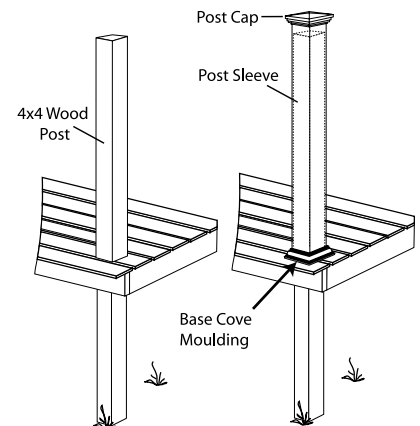

**Figure 2**

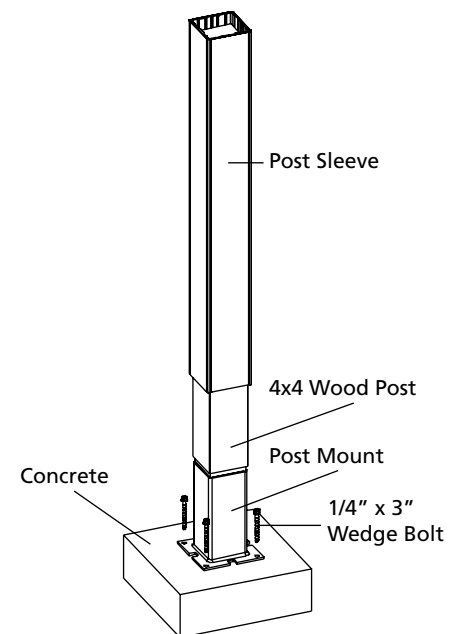

**Figure 3**

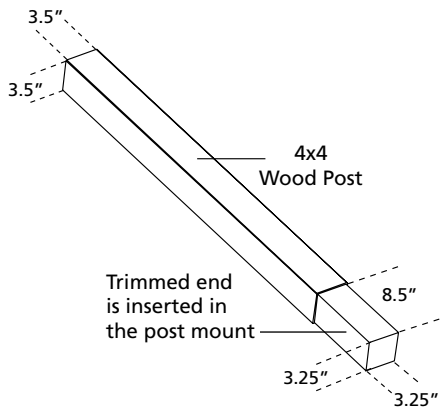

Figure 4

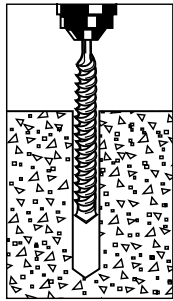

Figure 5

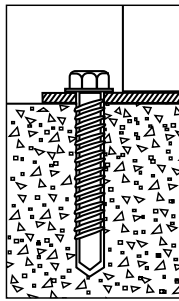

Figure 6

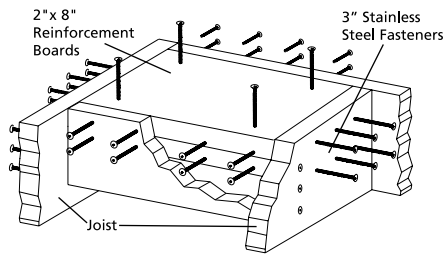

Figure 7

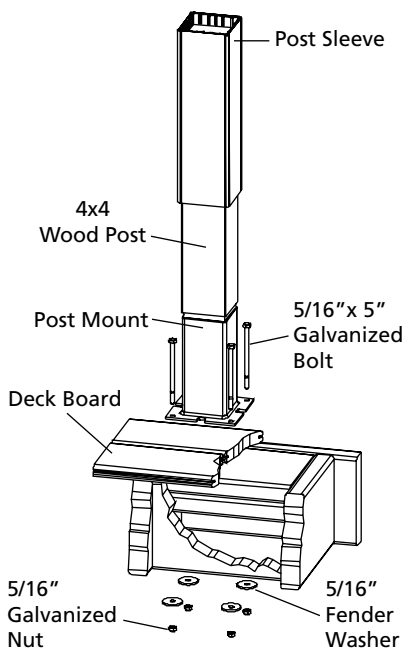

Figure 8

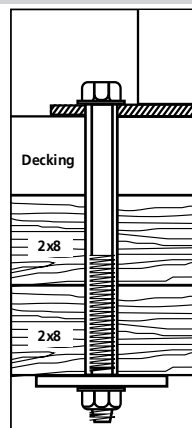

Figure 9

5. If necessary, trim the four sides of the wood post from one end to achieve the dimensions shown (Fig. 4).
6. Use the base of the mount as a template and mark the four corner holes for the concrete Wedge-Bolt™ Anchors (Included in kit).
7. Drill the marked holes using a 1/4" masonry drill bit. Drill the holes into the concrete base to a depth of at least 1/2" deeper than the length of the 1/4" x 3" Wedge Bolt™ Anchors. Blow the hole clean of dust and debris (Fig. 5).
8. Locate the mount by aligning the mount corner holes over the drilled holes.
9. Insert the trimmed end of the 4"x 4" wood post into the mount. Ensure that the post is plumb and true.
10. If necessary, place a shim under the mount to make the post plumb and true.
11. Insert the four concrete Wedge-Bolt™ Anchors into the corner holes of the mount. Begin tightening the Wedge-Bolt™ Anchor by rotating clockwise and applying pressure in toward the base. This will engage the first few threads as the Wedge-Bolt™ Anchor begins to advance. Continue to tighten until the head of the Wedge-Bolt™ Anchor is firmly seated against the post mount (Fig. 6). Repeat for the remaining Wedge-Bolt™ Anchors.
12. Slide the post sleeve over the 4"x 4" treated wood post until it contacts the base of the mount.

**For Wood:**

1. Determine the desired location(s) and finished height of the post sleeve from the deck surface.
2. The thickness of the wood/composite deck and reinforcement boards underneath the deck should be a minimum of 4". (Two treated and structurally sound 2"x 8" lumber under the deck board, Fig. 9). Fasten the reinforcement boards with 3" stainless steel fasteners as shown (Fig. 7).
3. Trim the post sleeve to the desired length.
4. Ensure the treated 4"x 4" (generally 3.5" x 3.5" actual) wood post is structurally sound and code compliant.
5. Trim the length of the 4"x 4" wood post. The wood post length is typically 1-2" shorter than the post sleeve length.
6. If necessary, trim the four sides of the wood post from one end to achieve the dimensions shown (Fig. 4)
7. Use the base of the mount as a template and mark the four corner holes on the deck surface. Mark inside square of bracket on deck surface.
8. Drill four 3/8" holes at the marked locations, drilling through the deck board and the reinforcement boards. Drill 3/8" drainage hole in square through deck board and reinforcement boards for drainage.
9. Locate the mount by aligning the mount corner holes over the drilled holes.
10. Insert the trimmed end of the 4"x 4" wood post into the mount. Ensure that the post is plumb and true.
11. If necessary, place a shim under the mount to make the post plumb and true.
12. Insert the 5/16" x 5" galvanized hex bolts into the mount holes and the drilled holes. (Galvanized bolts & nuts, not included)
13. Fasten the four bolts underneath the reinforcement boards with the 5/16" Fender washer (included in kit) and 5/16" galvanized hex nuts (Fig. 9).
14. Slide the post sleeve over the 4"x 4" treated wood post until it contacts the base of the mount.

## Joist Mount Brackets (sold separately)

Use Joist Mount Brackets on projects where framing is fully exposed (Fig. 1). In new construction, Joist Mount Brackets are attached to the inside of the framing before the porch flooring or decking is installed. Joist Mount Brackets may be used to install railing on existing decks provided the framing underneath is exposed to permit proper installation. Joist Mount Brackets can be used in a corner or line application and bolts directly to the framing with four galvanized carriage bolts. Follow these guidelines to complete the post installation:

*Note: When installing 8 foot sections in regions requiring 1999 Standard Code compliance, the standard Joist Mount Bracket may NOT be used. Use either the Pro Joist Mount Bracket, the Surface Mount Bracket or the vinyl sleeve option. When in doubt, check with your local Building Inspections Department.*

1. Determine position of the posts on the framing (Fig. 1).
2. Position Joist Mount Bracket flush with top of framing at each post location (Fig. 11).
3. Use the Joist Mount Bracket as a template for hole location. With a pencil, mark hole positions on the framing.
4. For corner posts, remove the side plate from the bracket (Fig. 11). Mark hole positions on framing (Fig. 12).
5. Drill holes at desired locations using a 7/16" drill bit.
6. Attach brackets to rim joists using four 3/8" x 3" galvanized carriage bolts, washers, and nuts (at this point, do not fully tighten).
7. Insert post into bracket until bottom of post contacts stop tab on bottom of bracket (Fig. 13).
8. Fully tighten carriage bolts and nuts to secure post in place. Ensure that post remains plumb.

## Surface Mount Brackets (kits sold separately)

Use the Surface Mount Brackets to install posts directly onto the deck or porch surface. Surface Mount Brackets are available for concrete or wood/composite surfaces. When installing a post on a concrete surface, the support system is anchored into the concrete. When installed on a wood or composite deck, the support system is installed after the deck surface has been attached. Follow these guidelines to complete the post installation:

### For Concrete: (Fig. 16)

1. Lay out the locations for the posts.
2. Use the base plate as a template and mark the four corner holes for the concrete Wedge-Bolt™ Anchors.
3. Drill the marked holes using a 1/4" masonry drill bit. Drill the hole into the concrete base to a depth of at least 1/2" deeper than the length of the 1/4" x 3" Wedge-Bolt™ Anchors. Blow the hole clean of dust and debris (Fig. 14).
4. Align the base plate over the drilled holes.
5. Position the post mount over the top of the base plate.
6. Screw the 5/16" leveling set screws into the four tapped holes. If needed, adjust the set screws to straighten the post.
7. Insert the four concrete Wedge-Bolt™ Anchors into holes located on the corners of the bottom plate. Begin tightening the Wedge-Bolt™ Anchors by rotating clockwise and applying pressure in toward the base. This will engage the first few threads as the Wedge-Bolt™ Anchors begin to advance. Continue to tighten until the head of the Wedge-Bolt™ Anchor is firmly seated against the post mount (Fig. 15).
8. Slide the composite post over the post mount until it contacts the concrete. The post sizing stabilizers will secure the composite post in proper position.

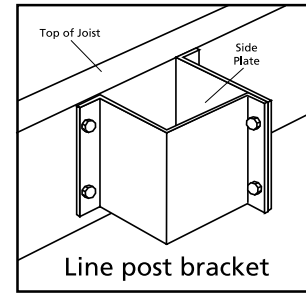

Figure 11

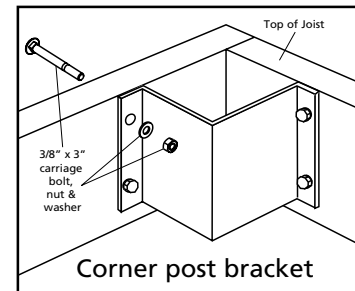

Figure 12

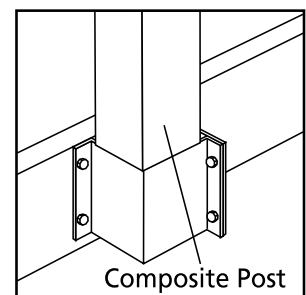

Figure 13

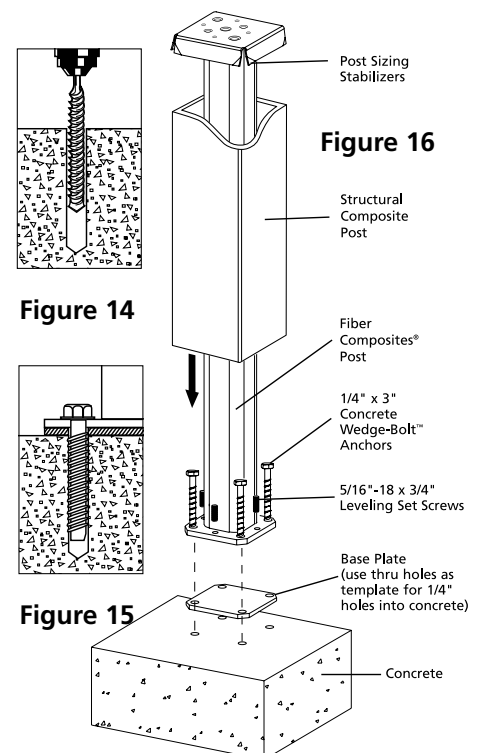

Figure 16

Figure 14

Figure 15

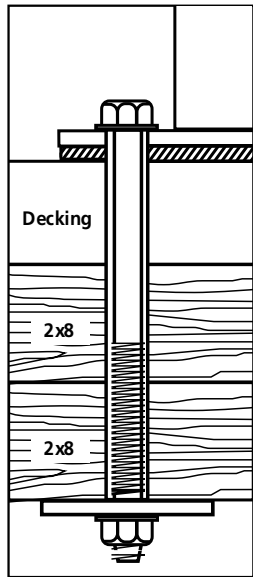

Figure 17

**For Wood: (Fig. 18 - Corner, Fig. 19 - Line)**

1. Lay out the locations for the posts.
2. Thickness of wood/composite deck and reinforcement boards underneath deck should be a minimum of 4". (Two treated 2" x 8" lumber under the deck board) (Fig. 17). Fasten reinforcement boards with 3" stainless steel fasteners as shown below (Fig. 7).
3. Use post mount as a template and mark the four corner holes for the 5/16" x 5-1/2" bolts.
4. Drill four 3/8" holes at the marked locations, drilling through the deck board and the reinforcement boards.
5. Align the base plates over the drilled holes as shown at left (Fig. 18).
6. Screw the 5/16" leveling set screws into the four tapped holes. If needed, adjust the set screws to straighten the post.
7. Insert the four 5/16" x 5-1/2" bolts into the drilled 3/8" holes.
8. Fasten the four bolts underneath the reinforcement boards with the 5/16" Fender washer and hex nut (Fig. 19).
9. Slide composite post over the post mount until it contacts the base plates. The post sizing stabilizers will secure the post in proper position.

Figure 18

**Corner Application**

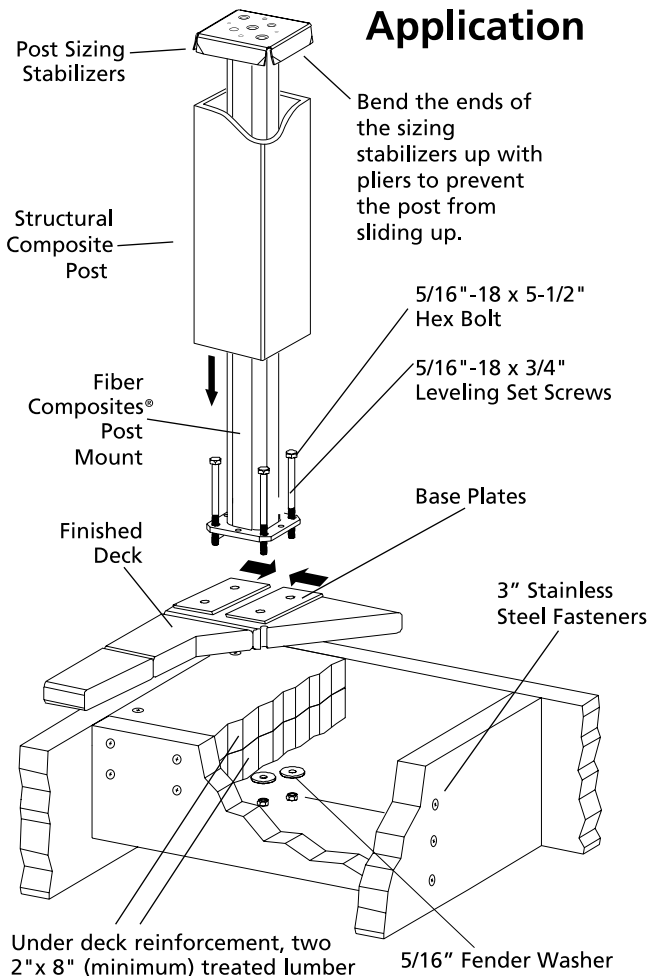

**Line Application**

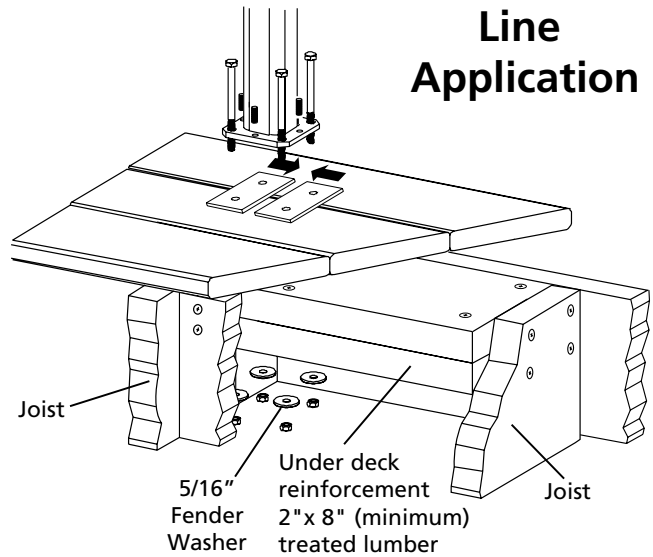

Figure 19

## Line rail Installation

1. Measure the distance between properly installed, plumb posts.
2. Mark the top rail for the inside distance between the posts. The distance from the end of the rail to the first baluster slots should be equal on both ends of the rail. Ensure that the bracket screws will fasten into the top rail and that none fall into the routed baluster slots.

*Note: Minimum distance from post to first baluster slot on top rail is 1 1/2".*

3. Place the bottom rail next to the top rail so that the top and bottom baluster slots are aligned. Mark the bottom rail for the inside distance between the posts.
4. Cut the top and bottom rails to fit tightly between the posts.
5. Center the bottom bracket on the underside of the bottom rail (Fig. 20). Inset the bottom bracket 1/16" from the end of the rail. Mark the three hole locations on the rail. Pre-drill 1/8" holes at the desired locations. Repeat for opposite end.
6. Secure the bottom bracket to the bottom rail using three #10 x 1" long screws. Repeat for opposite end. **DO NOT OVERTIGHTEN SCREWS.**
7. Center the top bracket on the underside of the top rail (Fig. 21). Inset the top bracket 1/16" from the end of the rail. Mark the three hole locations on the rail. Pre-drill 5/32" holes at the desired locations. Repeat for opposite end.
8. Secure the top bracket to the top rail using three #12 x 1" long screws. Repeat for opposite end. **DO NOT OVERTIGHTEN SCREWS.**
9. Ensure that the base cove moulding is in place at the bottom of the posts (Fig. 2).
10. Cut the crush block to the desired height (consult local building official for the proper spacing between the deck and the railing). Place crush block on the deck surface midway between the posts (Fig. 25).
11. Place the bottom rail between the posts and on the crush block. Ensure that the bottom rail is level and that the ends of the rail are centered on the post.
12. Mark on the post the two bottom bracket hole locations. Pre-drill 5/32" holes at desired locations. Repeat for opposite end.
13. Secure the bottom rail to the post using two #10 x 2" long screws. Repeat for opposite end. **DO NOT OVERTIGHTEN SCREWS.**

*Note: A flexible shaft bit holder (not included) is helpful during this step.*

14. Determine the desired baluster design (squared look, diamond look or a mixed pattern of the two) (Fig. 22).
15. Ensure that all of the balusters are of equal length. Trim if necessary.
16. Fully engage the bottom baluster insert (Fig. 23) into each baluster slot in the bottom rail. Orient the bottom baluster insert to achieve the desired look (Fig. 22).
17. Fully engage a baluster over each bottom baluster insert.
18. Fully engage the top baluster insert (Fig. 24) into each baluster slot in the top rail. Ensure that the top baluster insert is oriented the same as the corresponding bottom baluster insert.
19. Place the top rail between the post and above the top end of the balusters. Starting at one end of the rail, reposition top end of the baluster to allow the top baluster insert to engage it. Repeat for each baluster.
20. Once all of the balusters are engaged, gently push down on the top rail until the bottom end of the balusters contacts the bottom rail (Fig. 25). The flange of the top baluster insert should be tightly secured between baluster and the underside of the top rail.
21. Ensure that the top rail is level and that the rail ends are centered on each post.
22. Mark on the post the two top bracket hole locations. Pre-drill 5/32" holes at the desired locations. Repeat for opposite end.
23. Secure the top rail to the post using two #12 x 2" long screws. Repeat for opposite end. **DO NOT OVERTIGHTEN.**

*Note: A flexible shaft bit holder (not included) is helpful during this step.*

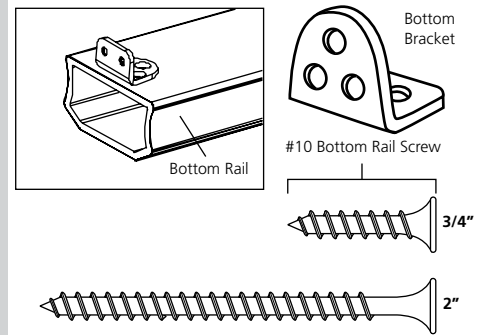

Figure 20

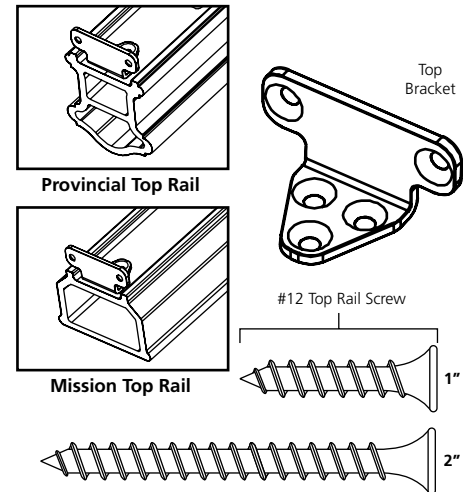

Figure 21

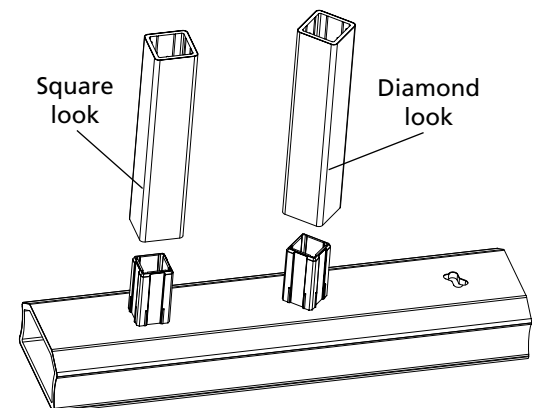

Figure 22

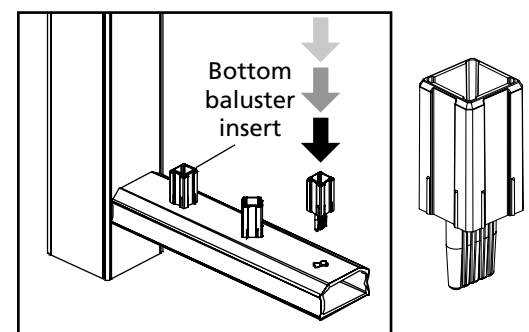

Figure 23

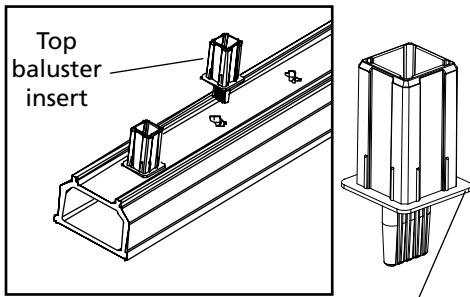

Figure 24

Flange

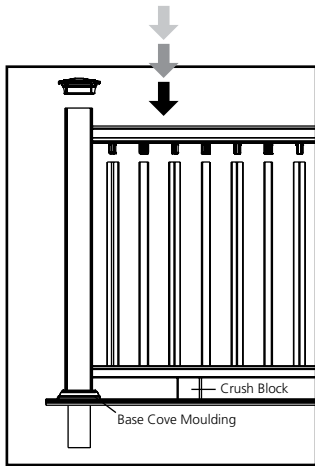

Figure 25

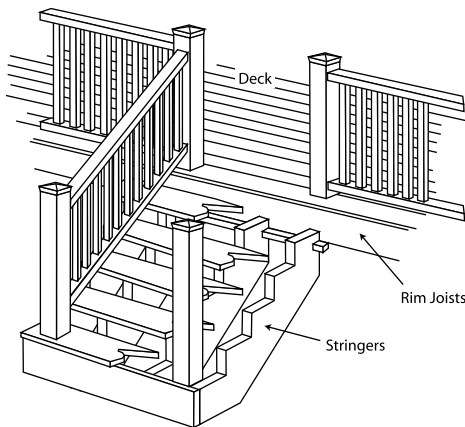

Figure 26

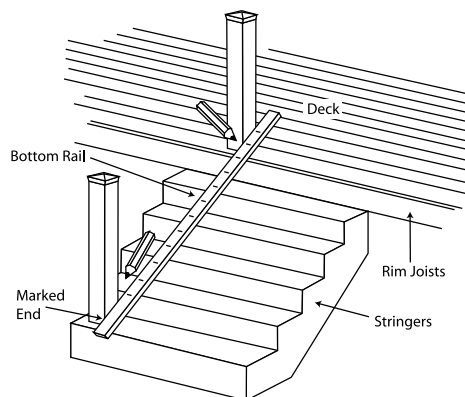

Figure 27

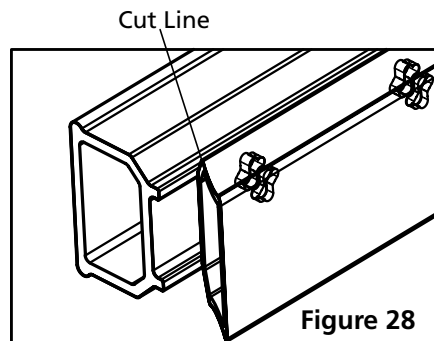

Figure 28

24. Using PVC cement, glue crush block to underside of bottom rail midway between the posts.
25. Mount and glue post caps after all rail section are installed.

### Stair Rail Installation (Requires stair rail kit)

*Note: The stair angle is a 32 degree angle which is equal to a 7" rise and an 11" run. Building codes are very specific on allowable angles and widths. It is very important to consult with your local building code officials and plan your stair layout accordingly. Ensure that you leave adequate space for graspable hand rail if applicable. "Dry fitting" intermediate post placement will result in easier and better looking installations and may avoid placement of post mounting brackets in areas where screws cannot attach to the guardrail.*

1. Position two line posts at top of stairway with the desired spacing and secure each post with the appropriate installation method (Fig. 26).
2. Install the outside stringers just wider than the post's location. The posts mounted at the bottom of the stairs will be on the inside of the stringer and must line up directly with the posts at the top of the stairs.

*Note: For stairs longer than six feet, it will be necessary to use multiple stair sections. The distance between posts, measured at an angle should not exceed 70 inches. Ensure all posts are plumb prior to final mounting.*

3. Lay bottom rail on stair with marked end at lower post. Center the rail between the posts so that the distance from the post to the first routed hole is equal on both ends. (Fig. 27).
4. Mark angles on the bottom rail.
5. Cut the bottom rail to length. Ensure that the rail fits tightly between the posts.
6. Place the top rail next to the bottom rail with the marked ends together. Using the bottom rail as a guide, center the routed holes in the top rail with the routed holes in the bottom rail. Mark the cut lines on the top rail (Fig. 28).
7. Cut the top rail to length.
8. Ensure that the base cove moulding is in place at the bottom of the posts (Fig. 29).
9. Center the hinged bracket on the underside of the bottom rail. Inset the hinged bracket 1/16" from the end of the rail. Mark the three bracket hole locations on the rail. Predrill 5/32" hole at the desired locations. Repeat for opposite end.
10. Secure the hinged bracket to the bottom rail using three #12 x 1" long screws. Repeat for opposite end. **DO NOT OVERTIGHTEN SCREWS.**
11. Repeat steps 8-9 for the top rail.
12. Lay the bottom rail, with the routed holes upward, onto a 1/4" wood spacer located between the posts (Fig. 29). This provides the rail spacing between the rail and stair treads and helps to stabilize the setup.
13. Using the hinged bracket as a template, swing the unsecured leg of the bracket downward so that it touches the post. Mark the two hole locations on the post. Repeat for opposite end.
14. Remove the bottom rail from between the posts.
15. Predrill 5/32" holes at desired bracket hole locations.
16. Place bottom rail between the posts. Secure the bottom rail to the post using two #12 x 2" long screws. Repeat for opposite end. **DO NOT OVERTIGHTEN.**

17. Fully engage the baluster inserts into the routed holes of the bottom rail (Fig. 30).
18. Mark the stair angle on one end of each baluster to be used (Fig. 29).
19. Cut the stair angle on one end of each baluster, cut the stair angle on half of the other end (Fig. 29).
20. Fully insert the top ends of the balusters into the routed holes of the top rail. The angled cut of the baluster should be parallel with the length of the top rail. (Fig. 29).
21. Place the top rail and balusters on top of the baluster inserts. Locate each baluster so that the baluster insert is engaged inside of the baluster.
22. Gently push down on the top rail until the bottom end of the balusters contacts the bottom rail.
23. Ensure that the top rail ends are centered on each post.
24. Using the hinged bracket as a template, swing the unsecured leg of the bracket downward so that it touches the post. Mark the two hole locations on the post. Repeat for opposite end.
25. Slightly pull the top of the rail section toward the staircase to gain access to holes. Predrill 5/32" holes at desired locations. Repeat for opposite end.
26. Secure top rail to post using two #12 x 2" long screws. Repeat for opposite end. **DO NOT OVERTIGHTEN SCREWS.**

### Angle Rail Installation *(Angle Bracket Kit available by Special Order)*

Rails up to 30 degrees may be mounted to the post face by using the In Line "L" Bracket (Fig 20). Rails should be cut at the appropriate angle to fit tight against post. Cutting rails greater than 30 degrees will result in a rail that does not fully fit on post. Angles greater than 30 degrees require the use of the Angle Mount Bracket.

1. Determine the angle of your installation by using the supplied template (located on the last page of this booklet).
2. Cut the template out along the appropriate marked lines. (You may want to photocopy the template as a backup prior to cutting).
3. Position the template on the non-routed flat side of the top rail. Mark the proper cutting angle (Fig. 31).
4. Position the template on the Non routed bottom surface of the bottom rail (Fig. 31). Mark the proper cutting angle. Template will be reversed from top rail.
5. Ensure baluster holes are equidistant from the end of rail to ensure proper vertical alignment.

*Note: Minimum distance from post corner to first square baluster hole 1 1/2".*

6. Make angle cuts in top and bottom rails.
7. Align the angled brackets with the 90 degree cut in the railing. Inset the bracket 1/16" from rails end. Mark the three screw hole locations on both rails. Repeat at opposite end. Predrill 1/8" holes at desired locations (Fig. 32).
8. After fitting angles to posts, follow the Line Rail instructions (Steps 6 through 22) to complete the rail section installation.

**fiberon**  
**HORIZON PLUS**™  
*Ultra Low Maintenance Composite Railing*

[www.fiberondecking.com](http://www.fiberondecking.com)

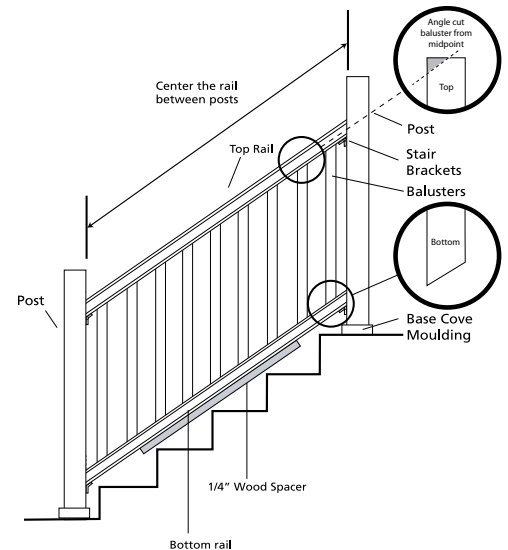

**Figure 29**

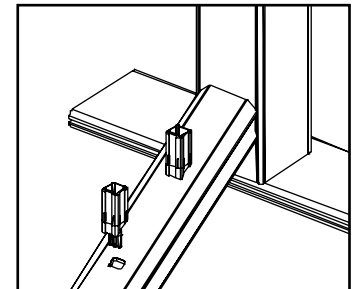

**Figure 30**

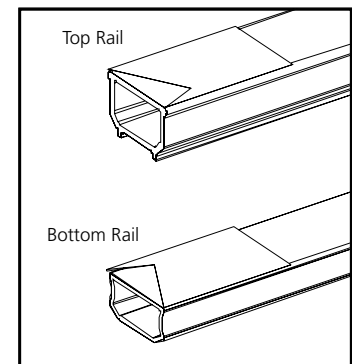

**Figure 31**

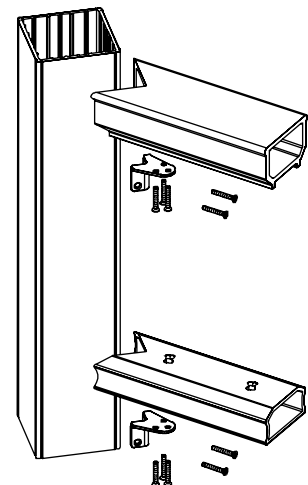

**Figure 32**

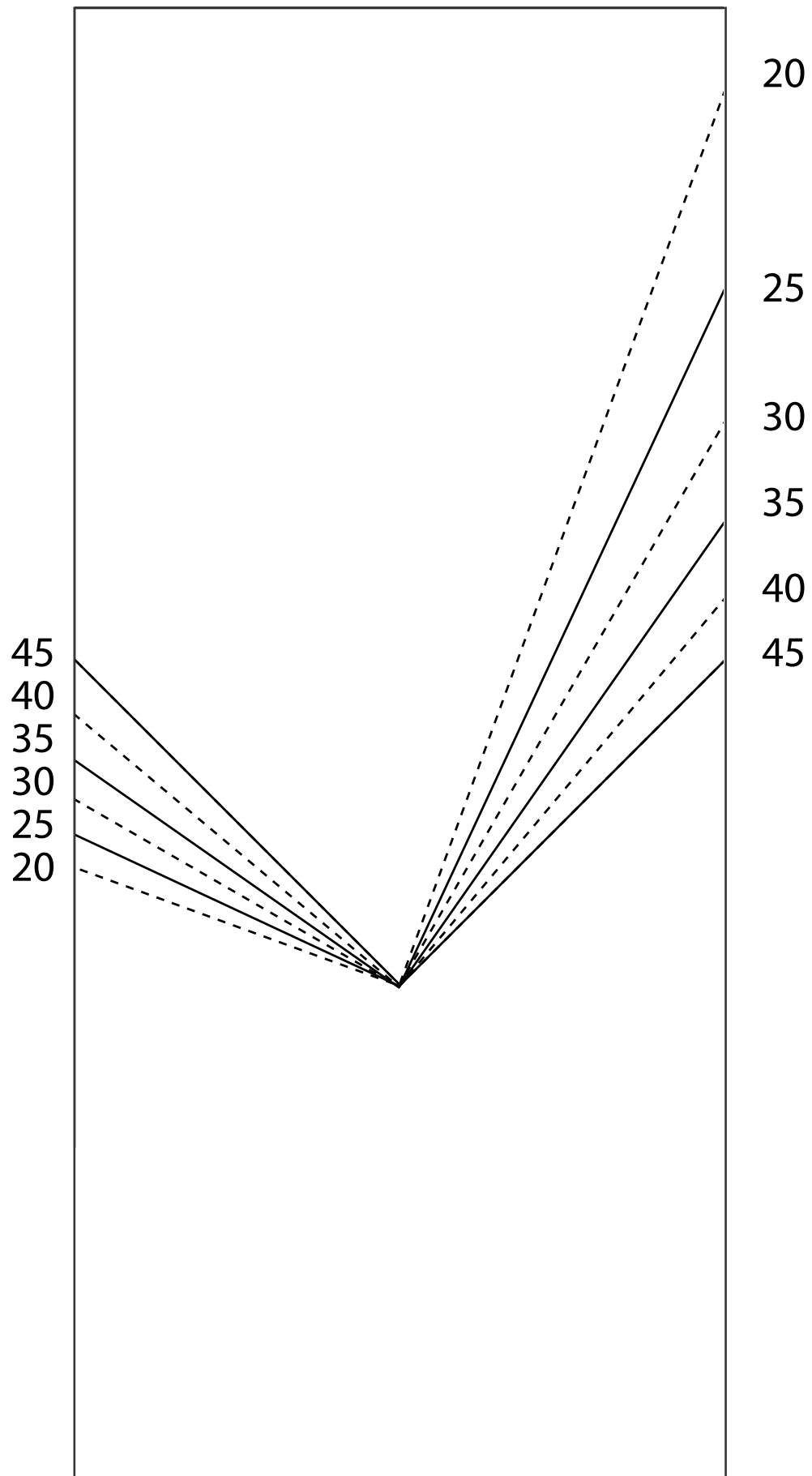

ANGLE RAIL CUTTING TEMPLATE

**fiberon**  
**HORIZON PLUS**™  
*Ultra Low Maintenance Composite Railing*